

Chris Watson Band

Stage Plot

Stage Left

Stage Right

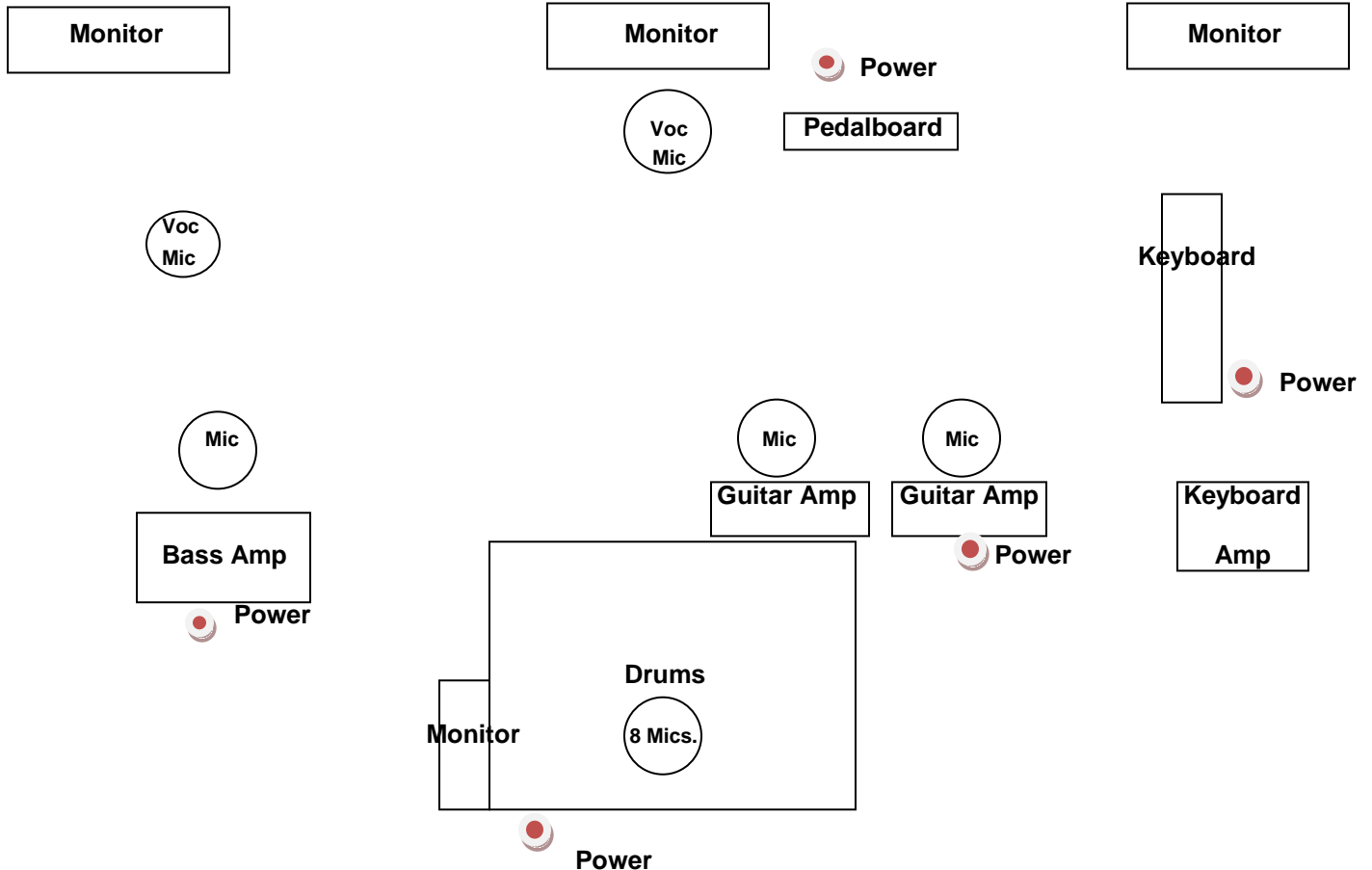

Input List:

1. Lead vocal mic
2. Vocal mic
3. Bass DI or amp mic
4. Guitar amp #1 mic
5. Guitar amp# 2 mic
6. Keyboard DI
7. Kick
8. Snare
9. High hat
10. RackTom
11. Floor Tom
12. Ride
13. Overhead #1
14. Overhead #2

Stage Monitor Requirements:

One wedge stage floor monitor for each musician (4 total) with high low speaker output using a single monitor mix.

Power:

Please provide 110 AC power to stage. Power drops need to be behind Bass Amp., behind Guitar amps., behind Drum riser, in front of Guitar Pedalboard at center stage, and at the Keyboard.

Lighting: Should cover the entire stage area.